

# Product Detail

# SNAP LOCK

## Snap Lock

### 16 Ga. - 24" Centers

Snap Lock provides bridging and spacing between interior, non-load bearing studs and exceptional resistance to stud rotation and displacement. The "snap" friction fit allows for installation with no screws.

#### Specifications

##### Channel:

- ASTM A653, structural grade 50, hot dipped galvanized steel
- Standard protective coating equal or superior to ASTM A653 coating designation G-60
- 16 Gauge
- Packaging: 25 pieces per carton
- Weight: 1.03 lbs./piece
- 24" Stud Centers

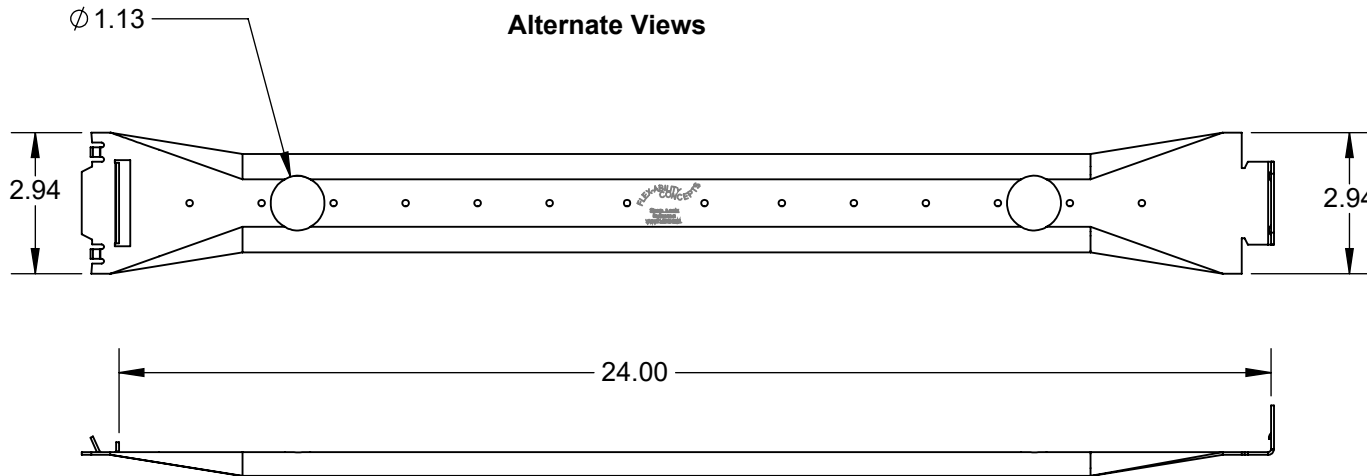
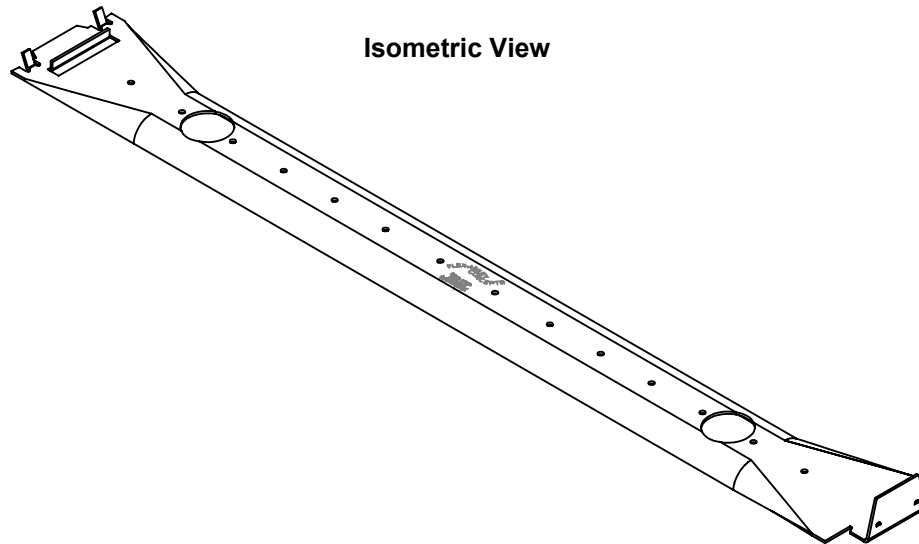

FLEX-ABILITY  
CONCEPTS

3840 N. Tulsa Ave.  
Oklahoma City, OK 73112  
Tel: 405-996-5343 Fax: 405-996-5353  
E-mail: [info@flexabilityconcepts.com](mailto:info@flexabilityconcepts.com)  
Web: [www.flexabilityconcepts.com](http://www.flexabilityconcepts.com)

Distributor:	Quantity:
Contractor:	Approved By:
Project:	Architect:
Product Detail: PDM53	Date: