

Product Detail

SNAP LOCK

Snap Lock

16 Ga. - 16" Centers

Snap Lock provides bridging and spacing between interior, non-load bearing studs and exceptional resistance to stud rotation and displacement. The "snap" friction fit allows for installation with no screws.

Specifications

Channel:

- ASTM A653, structural grade 50, hot dipped galvanized steel
- Standard protective coating equal or superior to ASTM A653 coating designation G-60
- 16 Gauge
- Packaging: 25 pieces per carton
- Weight: 0.69 lbs./piece
- 16" Stud Centers

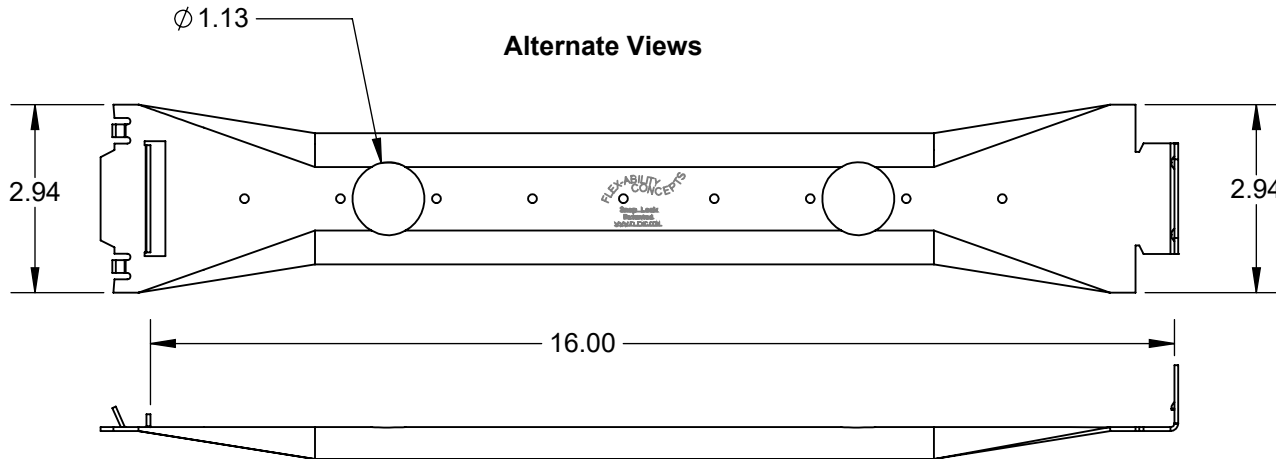
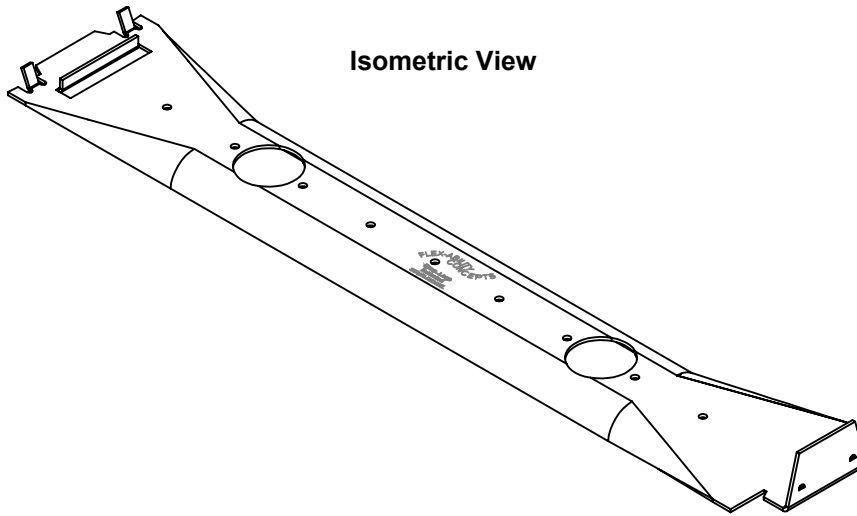

FLEX-ABILITY
CONCEPTS

3840 N. Tulsa Ave.
Oklahoma City, OK 73112
Tel: 405-996-5343 Fax: 405-996-5353
E-mail: info@flexabilityconcepts.com
Web: www.flexabilityconcepts.com

Distributor:
Contractor:
Project:
Product Detail: PDM52

Quantity:
Approved By:
Architect:
Date: