

FLEX-C HEADER™

Diagram A

3 Fasteners (Screws or Nails)
per block, each side

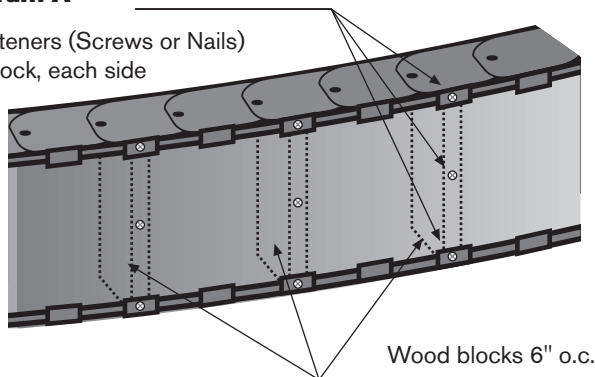

Wood blocks 6" o.c.



The flexible radius header can be shaped by hand to form a curve or S-shape. Once the header is in the desired curvature, it is locked in place by screws or nails and is ready for installation. Its unique construction makes it much lighter and easier to install than conventionally made curved headers. The header is available in 2"x 4", 2"x 6" sizes for wood framing, and in 3 5/8" and 6" widths for steel framing. For curved load bearing headers over doors and windows.

Installation instructions:

1. Before proceeding, refer to pages 3 & 4 to verify loading capacities and proper support placement(s).
2. Draw the desired curve on the floor or work surface.
3. Position the Flex-C Header on the line to match the radius.
4. Secure header in this curve by screwing into the top of the header through the pre-punched holes.
5. Slide side sheet metal so that at least six inches of it extends past the end of the curve. This will be used to secure the header to the framing later.
6. Now, fasten the side sheet metal to the wood blocks by installing screws or nails along the sides of the header, three per stud side, one fastener each through the sides of the top and bottom tracks, into the header blocks, and one fastener in the middle of the sheet metal and into the block. (See Diagram A)
7. Before lifting header into place install trimmer studs at each end and prepare temporary middle support stud.
8. Set header on trimmer and temporary middle support stud. Attach header to king studs through the overlapping side sheet metal. Also, fasten band to top plate of wall. Install

permanent middle support(s) as needed for door and/or window placement. (Refer to Diagram D)

9. All loads (i.e. joists and rafters) must make contact across the top entire width of the header.
10. If practical, point loads should be located directly over the stud blocks inside the header. If this is not practical, a wood "2by" or steel plate must be used under the point load, sufficiently long to distribute the load to two or more stud blocks.

TECHNICAL DATA

Lengths: 8'

Widths:

For Wood Studs: 2"x 4", 2"x 6"

For Steel Studs: 3 5/8" and 6"

Minimum Radius: 18"

	Thickness	Grade	Coating/Treatment
Side Steel Sheet	16 ga.	50	G60 or better
Flex-C Channel	20 ga.	33	G60 or better
Flex-C Strap	0.024"	80	G60 or better
Commercial wood blocks*	1 1/2"	#2	Fire Treated
Residential wood blocks*	1 1/2"	#2	_____

*Factory installed inside Flex-C-Header

Fasteners

Single Openings:

Screws: #10 x 1 1/4" self drilling ASTM C954-93—Not Provided

Nails: 0.131" x 1 1/2" Positive Placement Heat Treated—Not Provided

Multiple Openings:

Screws: #8 x 1 1/4" self drilling ASTM C954-93— Not Provided

Nails: 0.131" x 1 1/2" Positive Placement Heat Treated—Not Provided

PART 1 – GENERAL

1.1 DESCRIPTION

- A. Scope of Work: All interior and exterior load-bearing and non load-bearing light gauge steel and wood studs, track, joists, trusses, bridging, headers and related accessories are as indicated on the Contract Drawings and specified herein.
- B. Related work specified elsewhere.

1.2 SUMMARY

- A. This Section includes the following:
 - 1. Exterior and Interior load-bearing headers.

1.3 PERFORMANCE REQUIREMENTS

- A. Engineering Responsibility: Engage a fabricator who assumes undivided responsibility for engineering FLEX-C HEADER metal framing by employing a qualified professional engineer to prepare design calculations, shop drawings, and other structural data.
- B. All Exterior and Interior load-bearing applications are to be engineered by a qualified professional Engineer.

1.4 QUALITY ASSURANCE

- A. Installer Qualifications: Engage an experienced Installer who has completed cold-formed metal framing similar in material, design, and extent to that indicated for this project and with a record of successful in-service performance.
- B. Standard
 - 1. Work shall meet the requirements of the following standards:
 - a. American Iron and Steel Institute (A.I.S.I.) "Design of Cold Formed. Steel Structural Members," January 2002 edition.
 - b. American Society for Testing Materials (A.S.T.M.)
 - c. American Institute of Steel Construction (A.I.S.C.) "Manual of Steel Construction," 9th edition.
 - d. All pertinent Federal, State, and Local codes.
 - 2. The most stringent requirements shall govern in conflicts between specified codes and standards.
- C. Inspection
 - 1. As directed by Architect, Owner's testing agency may inspect the maintenance of a quality control program.
 - 2. Full responsibility for quality control shall remain with the Contractor.

1.5 DELIVERY, STORAGE, AND HANDLING

- A. Protect FLEX-C HEADER metal framing from corrosion, deformation, and other damage during delivery, storage, and handling.
- B. To store FLEX-C HEADER metal framing, protect with waterproof covering, and ventilate to avoid condensation.

1.6 SUBMITTALS

- A. Structural Calculations
 - 1. Submit structural calculations prepared by the Professional Engineer of record. Calculations shall include, but are not limited to:
 - a. Description of design criteria.
 - b. Engineering analysis depicting stress and deflection (stiffness) requirements for each framing application.
 - c. Selection of framing components and accessories.
 - d. Verification of attachments to structure and/or adjacent framing components.
- B. Drawings
 - 1. Submit drawings prepared by the manufacturer for approval by the Project Architect and Engineer. These drawings should include:
 - a. Component cross-sections, plans and/or elevations depicting component assembly.
 - b. Component assembly details showing screw types and locations and other related fastener requirements of component.

PART 2 – PRODUCTS

2.1 AVAILABLE MANUFACTURERS:

- A. Manufacturers offering FLEX-C HEADER metal framing that may be incorporated in the work include, and are limited to, the following:
 - 1. FLEX-ABILITY CONCEPTS - 3840 N. Tulsa Ave., Oklahoma City, OK 73112 | Tel 405.996.5343 | Fax 405.996.5353
www.flexabilityconcepts.com

2.2 MATERIALS

- A. Galvanized – 20 Ga. Steel Sheet Track (for 3 1/2" & 3 5/8"): ASTM A 653, and as follows:
 - 1. Coating Designation: Hot Dipped Galvanized Steel equal or superior to ASTM A653 G60 or A60.
 - 2. Grade: Structural Grade 33
- B. Galvanized – 20 Ga. Steel Sheet Track (for 5 1/2" & 6" track): ASTM A653, and as follows:
 - 1. Coating Designation: Hot Dipped Galvanized Steel equal or superior to ASTM A653 G60 or A60.
 - 2. Grade: Structural Grade 33
- C. Galvanized – Sliding Steel Strap (for all headers): ASTM A653
 - 1. Coating Designation: Hot Dipped Galvanized Steel Strapping equal or superior to ASTM A653 G60 or A60.
 - 2. Grade: Structural Grade 80
- D. Galvanized – 16 Ga. side sheet metal (for all FLEX-C HEADERS): ASTM 653
 - 1. Coating Designation: Equal or superior to ASTM A653 G60 or A60.
 - 2. Grade: Structural Grade 50.
- E. Wood Internal Components:
 - 1. Fire Treated (Commercial); Non Fire Treated (Residential)
 - 2. Grade: #2 or better.
- F. Nails (pre-installed):
 - 1. 0.104" dia. Shank knurled nail or equal.

2.3 HEADER FRAMING

- A. FLEX-C HEADER: manufacturer's standard rectangular flexible steel header with 3 1/2", 3 5/8", 5 1/2" or 6" FLEX-C TRAC flanges and nail attachments at every flange, fasteners penetrating top and bottom flanges at every wood support.

2.4 FRAMING ACCESSORIES

- A. Fabricate steel-framing accessories of the same material and finish used for framing members, with a minimum yield strength of 33,000 psi.
- B. Provide accessories of manufacturer's standard thickness and configuration, unless otherwise indicated.

2.5 FASTENERS (FOR INSTALLATION)

- A. Mechanical Fasteners:
 - 1. Single Openings: Screws: #10 x 1 1/4 Corrosion-resistant coated, self-drilling screws. Pan-head or low-profile head beneath sheathing, manufacturer's standard elsewhere.
 - 2. Multiple Openings: Screws: #8 x 1 1/4 Corrosion-resistant coated, self-drilling screws. Pan-head or low-profile head beneath sheathing, manufacturer's standard elsewhere.
 - 3. Nails: Positive Placement™ type. 11/2" x 0.131" heat treated.

2.6 MISCELLANEOUS MATERIALS

- A. Galvanizing Repair Paint: SSPC-Paint 20 of DOD-P-21035, with dry film containing a minimum of 94 percent zinc dust by weight.

2.7 FABRICATION

- A. Fabricate FLEX-C HEADER metal framing and accessories plumb, square, true to line, true to radius, and with connections securely fastened, according to manufacturer's recommendations and the requirements of this Section.
 - 1. Fabricate assemblies in jig templates or free form scribed radiuses.
 - 2. Cut FLEX-C HEADER metal framing by sawing or shearing; do not torch cut.
 - a. Extreme care should be taken when handling or cutting any metal products. Observe all safety precautions when handling, cutting or fastening FLEX-C HEADER.
 - 3. Fasten FLEX-C HEADER metal framing by screw fastening as standard with fabricator. Wire tying of FLEX-C HEADER framing members is not permitted.
 - a. Locate and install mechanical fasteners according to FLEX-C HEADER manufacturer's instructions with screws or nails penetrating banding at every wood support; 2 (two) penetrating top and bottom bands at every wood header block and 1 (one) penetrating each sheet metal side midpoint at every wood header block.
 - 4. Splice per manufacturer's specifications.
 - 5. Fasten other materials to FLEX-C HEADER metal framing by bolting, or screw fastening, according to manufacturer's recommendations.
- B. Reinforce, stiffen, and brace framing assemblies to withstand handling, delivery, and erection stresses. Lift fabricated assemblies to prevent damage or distortion.
- C. Fabrication Tolerances: Fabricate assemblies as required.

PART 3 – EXECUTION

3.1 INSTALLATION, GENERAL

- A. FLEX-C HEADER metal framing may be shop or field fabricated for installation, or it may be field assembled.
- B. Install FLEX-C HEADER metal framing and accessories plumb, square, true to line, true to radius, and with connections securely fastened, according to manufacturer's recommendations and the requirements of this Section.
 - 1. Cut FLEX-C HEADER members by sawing or shearing; do not torch cut.
 - a. Extreme care should be taken when handling or cutting any metal products. Observe all safety precautions when handling, cutting or fastening FLEX-C HEADER.
 - 2. Fasten FLEX-C HEADER members by screw fastening as standard with fabricator. Wire tying of FLEX-C HEADER members is not permitted.
 - a. Locate and install mechanical fasteners according to FLEX-C HEADER manufacturer's instructions with screws or nails penetrating banding at every wood header block; 2 (two) penetrating top and bottom bands at every wood header block and 1 (one) penetrating each sheet metal side midpoint at every wood header block.
 - 3. Splice per manufacturer's specifications.
- C. Install FLEX-C HEADER members in one or multi-piece lengths as specified.
- D. Verify splicing of FLEX-C HEADER with Engineer of record. See Manufacturer's standard splicing instructions to verify overlap requirements.
- E. Provide temporary bracing and leave in place until framing is permanently stabilized.
- F. Do not bridge building expansion and control joints with FLEX-C HEADER metal framing. Independently frame both sides of joints.
- G. Fasten reinforcement plate over web penetrations that exceed size of manufacturer's standard punched openings.

3.2 REPAIRS AND PROTECTION

- A. Galvanizing Repairs: Prepare and repair damaged galvanized coatings on fabricated and installed FLEX-C HEADER metal framing with galvanizing repair paint according to ASTM A 780 and the manufacturer's instructions.
- B. Touchup painting: Wire brush, clean, and paint scarred areas, welds, and rust spots on fabricated and installed prime-painted FLEX-C HEADER metal framing.
 - 1. Touchup painted surfaces with same type of shop paint used on adjacent surfaces.
- C. Provide final protection and maintain conditions in a manner acceptable to manufacturer and installer to ensure that FLEX-C HEADER metal framing is without damage or deterioration at the time of Substantial Completion.

FLEX-C HEADER

Technical Sheet

Proper Layout for Flex-C Header Supports

1 – All header assemblies which do not meet the single opening conditions (See page 4) must be supported by a **MINIMUM** of three supports. Please refer to diagrams B and C.

2 – Maximum clear span in a **single** opening assembly is 42". See Chart 3. Maximum clear span in a **multiple** opening assembly is 12". See Charts 1 and 2.

3 – Splices must be within two (2) feet of a support.
 – All splices must be performed according to the manufacturer's detailed instructions. See below.

4 – To locate supports calculate the ratio of every adjacent span. This ratio must be greater than 1/2 and less than 2. Use this formula:

$$\text{Ratio} = \frac{\text{Clear Span Length A}}{\text{Clear Span Length B}}$$

Assuming equal loading, this formula will result in the middle support being located within the middle third portion of the two adjacent spans. Please refer to diagram D. This ratio formula must also be applied to each pair of adjacent spans of a multiple span assembly, i.e. A-B, B-C, C-D, D-E. See Diagram E. Point loads or Uniform loads must be symmetrically and evenly spaced in relation to adjacent spans.

5 – Inflection points (points where curve reverses direction) **MUST** be supported.

Loads must not exceed the values listed in the Load Capacities Multiple Opening Tables published by Flex-Ability Concepts. See page 4.

To Cut Flex-C Header

Use a reciprocating saw, abrasive blade or tin snips. Always use proper safety precautions when handling or cutting Flex-C Header.

To Splice Flex-C Header

Overlap top and bottom tracks and screw in line with desired curve. Overlap the ends of all the side sheet metal pieces at least 18" by sliding them along the inside flanges of the top and bottom tracks, and fasten each side with three columns of three screws or nail into wood blocks (9 on each side). If these sets of three fasteners are not within 11/2" of each end of each splice, add another column of three screws within 11/2" of the ends of the splice overlap.

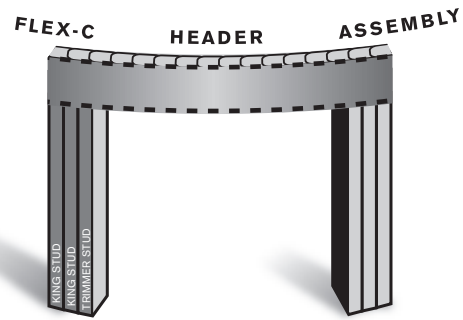

Diagram B
 Flex-C Header can be used over single openings only under very specific conditions. (See page 4)

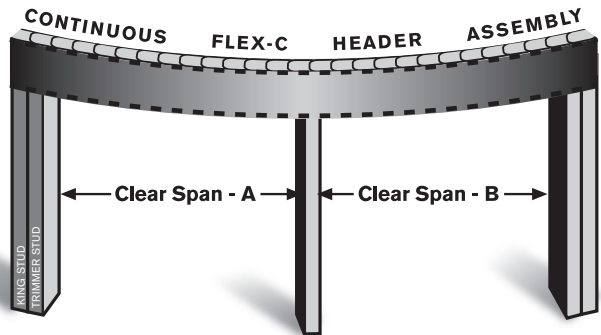

Diagram C
 All Flex-C Header assemblies which do not meet the single opening conditions (See page 4) must extend over two or more spans (must have a minimum of three supports).

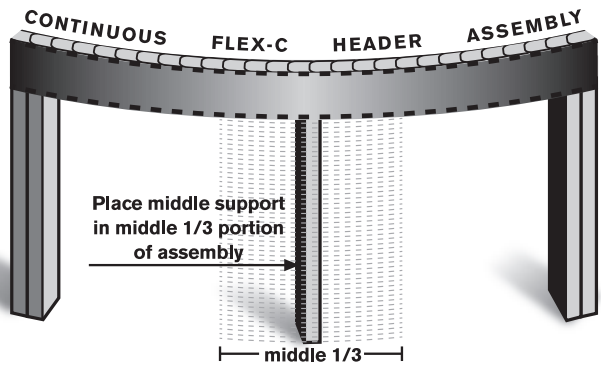

Diagram D
 Support must be located anywhere in the middle third portion of the two adjacent spans.

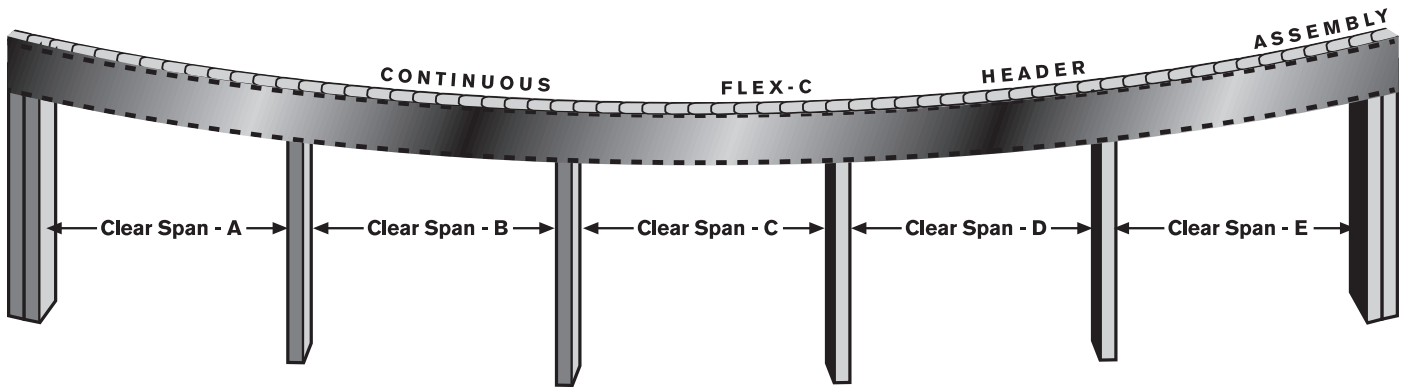

Diagram E
 Supports must be located anywhere in the middle third portion of each pair of adjacent spans.

Load capacity - Always refer to the Flex-C Header Design Load Tables, Charts 1&2 to verify that the loads determined by the engineer of record for each specific job are in line with the recommended capacities.

Design Load Tables Located on Page 4

Flex-C Header

Design Load Tables

CHART 1 **LOAD CAPACITIES MULTIPLE OPENING**
(Test data is available upon request.)

3 1/2" x 11 1/2" 3 5/8" x 11 1/2"		
Clear Span (ft)	Point Load (lbs)	Uniform Load (plf)
2.5	2877	2302
3.0	2398	1598
3.5	2055	1174
4.0	1800	899
4.5	1600	710
5.0	1440	575
5.5	1309	475
6.0	1200	399
6.5	1108	340
7.0	1028	293
7.5	960	255
8.0	900	224
8.5	847	199
9.0	800	177
9.5	758	159
10.0	720	143
10.5	685	130
11.0	654	118
11.5	626	108
12.0	600	99

CHART 2 **LOAD CAPACITIES MULTIPLE OPENING**
(Test data is available upon request.)

5 1/2" x 11 1/2" 6" x 11 1/2"		
Clear Span (ft)	Point Load (lbs)	Uniform Load (plf)
2.5	2927	2342
3.0	2439	1626
3.5	2091	1195
4.0	1829	914
4.5	1626	722
5.0	1463	585
5.5	1330	483
6.0	1219	406
6.5	1126	346
7.0	1045	298
7.5	975	260
8.0	914	228
8.5	861	202
9.0	813	180
9.5	770	162
10.0	731	146
10.5	697	132
11.0	665	120
11.5	636	110
12.0	609	101

Single Opening Conditions

1. Single, unsupported, span not to exceed 42".
2. Single span and radius dimensions must not be less than the corresponding value on chart 3 below.
3. Framing must include triple 2x's (2 bys) at both end supports 3 king studs or 2 king studs and 1 trimmer stud.
4. Four #10x11/4" screws in each king stud side, 36 or 48 total.

CHART 3

Minimum Allowable Outside Radius Per Span and Header Width

Span in inches	Header Width		
	3 5/8"	5 1/2"	6"
12	18.00	18.00	18.00
13	18.00	18.00	18.00
14	18.00	18.00	18.00
15	18.00	18.00	18.00
16	18.00	18.00	18.00
17	18.00	18.00	18.00
18	18.00	18.00	18.00
19	18.50	18.00	18.00
20	20.36	18.00	18.00
21	22.31	18.00	18.00
22	24.36	18.00	18.00
23	26.50	18.00	18.00
24	28.74	18.25	18.00
25	31.07	19.61	18.13
26	33.50	21.03	19.40
27	36.06	22.50	20.73
28	38.65	24.03	22.10
29	41.36	25.61	23.53
30	44.17	27.25	25.00
31	47.07	28.94	26.53
32	50.07	30.69	28.10
33	53.17	32.50	29.73
34	56.36	34.36	31.40
35	59.65	36.28	33.13
36	63.03	38.25	34.90
37	66.50	40.28	36.73
38	70.07	42.36	38.60
39	73.74	44.50	40.53
40	-	46.69	42.50
41	-	48.94	44.53
42	-	-	46.60

Minimum Allowable Radius in Inches